

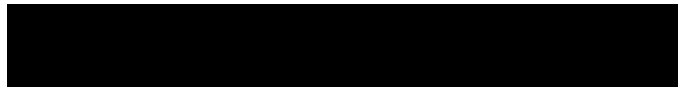

POLYCOM®

Installing the
iPower™ 70
Room Camera



Copyright © 2000-2002: Polycom, Inc.
Polycom, Inc., 4750 Willow Road, Pleasanton, CA 94588
www.polycom.com

Polycom and the Polycom logo are registered trademarks of Polycom, Inc. Concorde, Venue, and WorldCart are trademarks of PictureTel Corporation.

Velcro is a registered trademark of Velcro USA, Inc.

All other company and product names are the trademarks or registered trademarks of their respective owners.

The information contained in this document is subject to change without notice. Polycom assumes no responsibility for technical or editorial errors or omissions that may appear in this document or for the use of this material. Nor does Polycom make any commitment to update the information contained in this document. This document contains proprietary information which is protected by copyright. All rights reserved. No part of this document may be photocopied or reproduced in any form without the prior written consent of Polycom, Inc.

Edition: 3725-50453-001/A

Do you have any suggestions or comments on the documentation you received? If so, please send them by e-mail to iDesign@pictel.com .
--

Note: In this document, the term “monitor” is used to refer to the NTSC or PAL television (TV) broadcast receiver that is part of the collaboration system. These receivers are governed by different regulations than computer monitors.

FCC Notice

This equipment has been tested and found to comply with the limits for a Class A digital device, pursuant to Part 15 of the FCC Rules. These limits are designed to provide reasonable protection against harmful interference in a residential installation. This equipment generates, uses, and can radiate radio frequency energy and, if not installed and used in accordance with the instructions, may cause harmful interference to radio communications. However, there is no guarantee that interference will not occur in a particular installation. If this equipment does cause harmful interference to radio or television reception, which can be determined by turning the equipment off and on, the user is encouraged to try to correct the interference by one or more of the following measures:

- Reorient or relocate the receiving antenna.
- Increase the separation between the equipment and receiver.
- Connect the equipment into an outlet on a circuit different from that to which the receiver is connected.
- Consult the dealer or an experienced radio/TV technician for help.

The shielded cables provided with this equipment should be used to ensure compliance with the pertinent RF emission limits governing this device. Where no cable is provided, shielded interconnection cables should be used.

Notice to Canadian Users

This Class A digital apparatus meets all requirements of the Canadian Interference-Causing Equipment Regulations.

Cet appareil numérique de la classe A respecte toutes les dispositions du règlement sur les interférences radioélectriques du Canada.

Installing the iPower 70 Room Camera

About this Booklet

This booklet describes how to install the iPower[®] 70 room camera. The iPower 70 is a pan-tilt-zoom (PTZ) camera that is used with a iPower collaboration system as a main or an auxiliary camera.

This booklet contains information on:

- ❑ Before you install (page 4)
- ❑ Unpacking the box (page 5)
- ❑ Important note (page 6)
- ❑ Attaching the camera to a monitor (page 7)
- ❑ Connecting the camera cable to the collaboration system (page 8)
- ❑ Connecting an additional power cable (page 9)
- ❑ Service and support (page 10)
- ❑ Specifications (page 10)

Refer to the collaboration system documentation for instructions on how to use this camera.

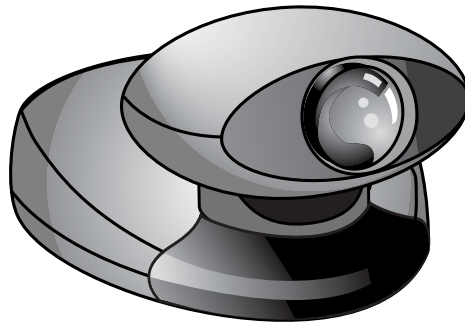

Before Installing

Warning

Before you begin this procedure, make sure you turn off your collaboration system's power switch.

To install this camera, you will need:

- ❑ The 8-pin camera cable **a** (labeled with the  icon on both cable collars) that came with your collaboration system, the WorldCart™, or the Premier Cart. (A camera cable is *not* supplied with this camera.)
- ❑ One of the following systems:
 - iPower 900 system, software version 1.0 or higher
 - Concorde•4500™ system, software version 6.50 or higher
 - Venue•2000™ system, software version 1.3.50 or higher
- ❑ A pencil
- ❑ A flashlight (optional)

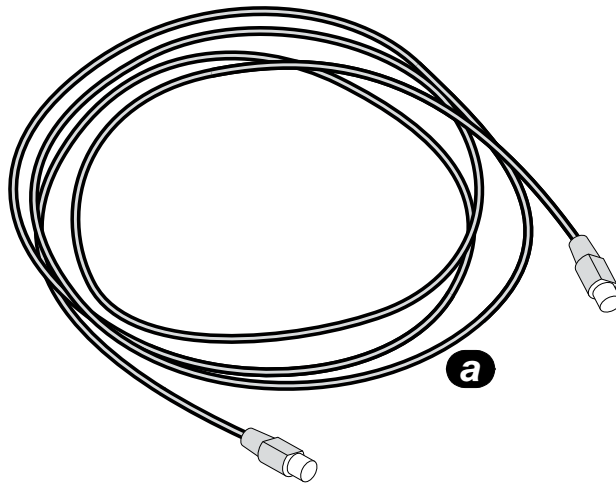

Unpacking the Box

To remove the camera from the box:

- 1. With two hands, grasp the outside edges of the packing material and gently lift the unit from the box.**
- 2. Carefully remove the camera from the packing material and place it on a flat surface.**

Caution

When lifting the iPower 70 camera, always lift the unit by its base. Never lift the camera by its head.

Note: Before you continue with the installation of the camera, please read the next section, "Important Note About Moving the Camera."

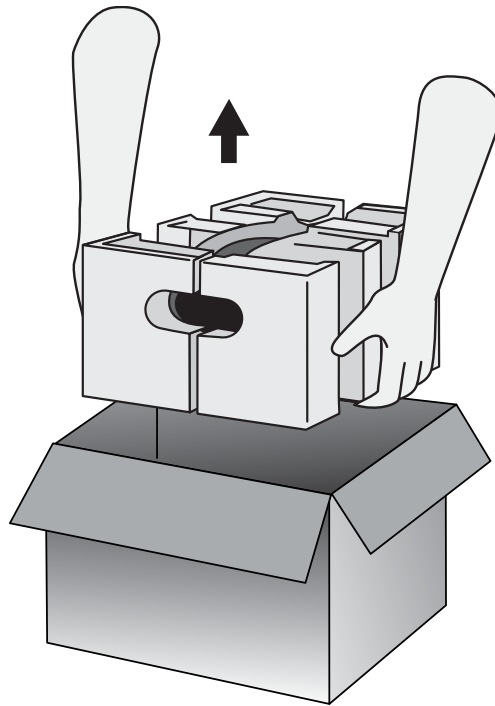

Important Note About Moving the Camera

The iPower 70 camera is designed to be controlled (moved) from the collaboration system wireless keypad, the keyboard, or the remote control. Be sure that your system is turned on before you move the camera.

You should not manually move the camera from side to side (pan) or up and down (tilt).

If you manually move the iPower 70 camera head, you may experience unexpected camera pointing behavior when you use camera presets.

To correct this condition, use the wireless keypad or the remote control to do the following:

- 1. Press and hold the near-end right arrow button until the camera rotates as far right as it can.***
- 2. Press and hold the near-end left arrow button until the camera rotates as far left as it can.***
- 3. Press and hold the near-end up arrow button until the camera moves up as far as it can.***
- 4. Press and hold the near-end down arrow button until the camera moves down as far as it can.***

If the condition persists,

Power the collaboration system off and then on again.

Attaching the Camera to a Monitor

Note: If you are installing a second monitor for a iPower 900 system, be sure to install the iPower 70 camera on the NTSC or PAL monitor and *not* on the VGA monitor. If you are installing a second monitor for a Concorde•4500 or Venue•2000 system, be sure to install the iPower 70 camera on the main monitor and *not* on the graphics monitor.

To attach the camera to the monitor:

1. **Clean the top of the monitor using a dry cloth. This helps the adhesive on the bottom of the Velcro® to adhere securely.**
2. **Without removing the backing from the adhesive strips, position the camera on the top center of the monitor with the front base of the camera within 0.75 inch (2 centimeters) of the front of the monitor **a**.**
3. **With a pencil, mark the top of the monitor to indicate exactly where you will be attaching the camera.**
4. **Remove the camera from the monitor and peel off the adhesive backing from the Velcro strips.**
5. **Align the camera with the marks you made and firmly press it onto the top of the monitor.**

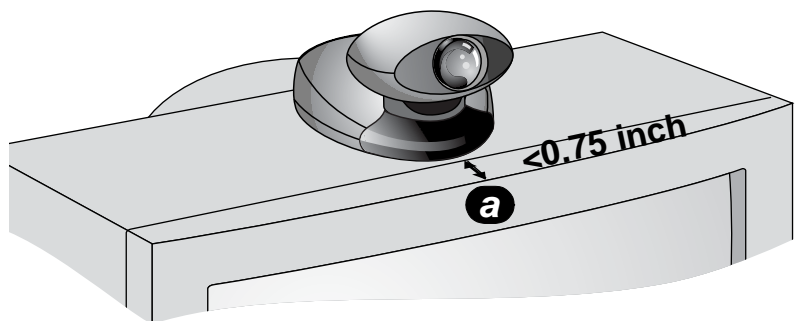



Connecting the Camera Cable

Caution

Whenever you plug a cable into this camera, hold the camera by its base, not by the camera head.

To connect the camera cable:

1. Plug the 8-pin camera cable **a** (labeled with the **b** icon on both cable collars) into the 8-pin camera connector **b** on the back of the camera.
2. Locate the desired camera connector (labeled with the **b** icon) on the back of the collaboration system computer box or electronics module **c**. (Choose  for main camera or  for auxiliary camera.)
3. Plug the other end of the camera cable into the desired camera connector **c**.

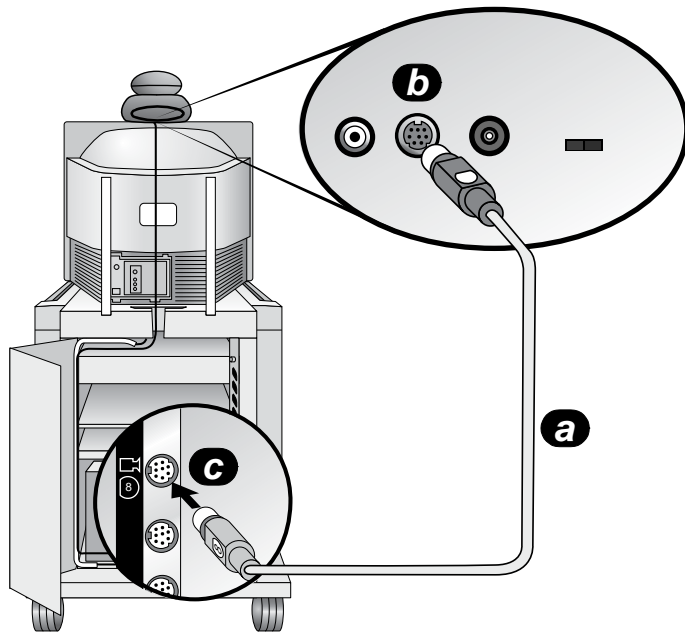

Connecting an Additional Power Cable

Although the camera cable provides power to the iPower 70 camera, if you are using a camera cable longer than 32.8 feet (10 meters), you must use an additional power cable for the camera.

To connect an additional power cable:

- 1. Plug the additional power cable into the power connector on the back of the camera **a**.**
- 2. Plug the other end of this cable into an appropriate power source.**

If you are in the process of installing an entire collaboration system, you may now return to your collaboration system installation instructions.

If you are mounting this camera on a tripod, refer to the mounting instructions included with your tripod mounting kit.

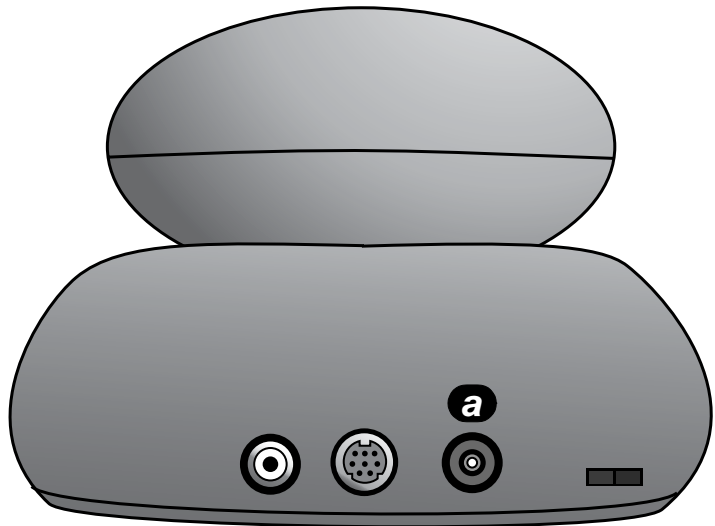

Service and Support

For support or service, please contact your Polycom service provider or call Polycom Technical Support. You can find phone numbers for Technical Support in your area at the Polycom web site, www.polycom.com.

Specifications

Physical Specifications

Dimensions: Length: 7.2 in. (18.3 cm)
 Width: 7 in. (17.8 cm)
 Height: 5.4 in. (13.7 cm)

Weight: 3.5 lb. (1.6 kg)

Operating and Nonoperating Environments

Temperature: Operating: 32° to 104° F (0° to 40° C)
 Nonoperating: -40° to 158° F (-40° to 70° C)

Humidity: Operating: 15% to 75% (Noncondensing)
 Nonoperating: 0% to 90% (Noncondensing)

Operating Specifications

Field of View: 66°

Pan Range: ±100°

Tilt Range: +15°/-30°

Zoom: 12x, autofocus

Resolution: 410,000 pixel, 0.25 in. (6 mm) CCD,
 430 HTVL

Video Standard: NTSC or PAL

Power: +12V DC