



SpectraLink 8000 SVP Server

SVP100, SVP020, SVP010

Administration Guide

for SIP

August 2011 Edition
1725-36033-001
Version F



Patent Information

The accompanying product is protected by one or more US and foreign patents and/or pending patent applications held by Polycom, Inc.

Copyright Notice

© 2009 to 2011, Polycom, Inc. All rights reserved. POLYCOM®, the Polycom "Triangles" logo and the names and marks associated with Polycom's products are trademarks and/or service marks of Polycom, Inc. and are registered and/or common law marks in the United States and various other countries. All other trademarks are property of their respective owners. No portion hereof may be reproduced or transmitted in any form or by any means, for any purpose other than the recipient's personal use, without the express written permission of Polycom.

All rights reserved under the International and pan-American copyright Conventions.

No part of this manual, or the software described herein, may be reproduced or transmitted in any form or by any means, or translated into another language or format, in whole or in part, without the express written permission of Polycom, Inc.

Do not remove (or allow any third party to remove) any product identification, copyright or other notices.

Every effort has been made to ensure that the information in this document is accurate. Polycom, Inc. is not responsible for printing or clerical errors. Information in this document is subject to change without notice and does not represent a commitment on the part of Polycom, Inc.

Notice

Polycom, Inc. has prepared this document for use by Polycom personnel and customers. The drawings and specifications contained herein are the property of Polycom and shall be neither reproduced in whole or in part without the prior written approval of Polycom, nor be implied to grant any license to make, use, or sell equipment manufactured in accordance herewith.

Polycom reserves the right to make changes in specifications and other information contained in this document without prior notice, and the reader should in all cases consult Polycom to determine whether any such changes have been made.

NO REPRESENTATION OR OTHER AFFIRMATION OF FACT CONTAINED IN THIS DOCUMENT INCLUDING BUT NOT LIMITED TO STATEMENTS REGARDING CAPACITY, RESPONSE-TIME PERFORMANCE, SUITABILITY FOR USE, OR PERFORMANCE OF PRODUCTS DESCRIBED HEREIN SHALL BE DEEMED TO BE A WARRANTY BY POLYCOM FOR ANY PURPOSE, OR GIVE RISE TO ANY LIABILITY OF POLYCOM WHATSOEVER.

Contact Information

Please contact your Polycom Authorized Reseller for assistance.

Polycom, Inc.
4750 Willow Road,
Pleasanton, CA 94588
<http://www.polycom.com>

About This Document

This document explains how to configure and maintain one or more SpectraLink 8000 SVP Servers (models SVP100, SVP020, SVP010) within IP telephony environments.

Polycom Model Numbers

This document covers the following registered model number:
SVP100

Related Documents

SpectraLink 8020/8030 Wireless Telephone: Administration Guide for SIP
(1725-36038-001)

Available at

<http://www.polycom.com/usa/en/support/voice/wi-fi/wi-fi.html>

Polycom VIEW Certified Products Guide (1725-36040-001)

VIEW Configuration Guide 1725-36xxx-001 where xxx indicates a number corresponding to the type of access point)

Available at

http://www.polycom.com/support/voice/wi-fi/view_certified.html

*Deploying Enterprise-Grade Wi-Fi Telephony
Best Practices Guide for Deploying SpectraLink 8020/8030 Wireless
Telephones*

Available at

http://www.polycom.com/products/voice/wireless_solutions/wifi_communications/handsets/spectralink_8020_wireless.html

Customer Support

Polycom wants you to have a successful installation. If you have questions, please contact our Customer Support Hotline at (800) 775-5330.

The hotline is open Monday through Friday, 6 a.m. to 6 p.m. Mountain time.

For Technical Support: technicalsupport@polycom.com

For Knowledge Base:
<http://www.polycom.com/usa/en/support/voice/voice.html>

For Return Material Authorization: rmaordinator@polycom.com

Icons and Conventions

This manual uses the following icons and conventions.



Caution! Follow these instructions carefully to avoid danger.



Note these instructions carefully.

Label

This typeface indicates a key, label, or button on Polycom hardware.

Contents

0	About This Document	3
	Polycom Model Numbers	3
	Related Documents	3
	Customer Support	4
	Icons and Conventions	4
1	SpectraLink 8000 SVP Server Overview	7
	SpectraLink Voice Priority (SVP) and Quality of Service	7
	SpectraLink 8000 SVP Server Models	8
	The Timing Function	8
	Multiple SVP Servers	8
	Multiple SVP Server Capacities	10
	Notes on System Configuration	12
	System Diagram	13
	System Components	14
	The Front Panel of the SVP Server	16
2	Installing the SpectraLink 8000 SVP Server	19
	Required Materials	19
	Locate the SVP Server	20
	Install the SVP Server	20
3	Configuring the SpectraLink 8000 SVP Server	23
	Connecting to the SVP Server	23

The NetLink SVP-II System Menu	24
Network Configuration.....	25
SendAll	26
SVP Server Configuration.....	29
QoS Configuration.....	33
Change Password.....	35
4 Swapping/Adding/Deleting SVP Servers	37
Adding an SVP Server.....	37
Removing an SVP Server	37
SVP Server Failure	38
5 Software Maintenance	39
Software Updates.....	39
6 Troubleshooting via System Status Menu.....	41
Error Status	42
Network Status.....	43
Software Version	45
7 Safety Notices	47

SpectraLink 8000 SVP Server Overview

The SpectraLink 8000 SVP Server is an Ethernet LAN device that works with access points (APs) to provide QoS on the wireless LAN. Voice packets to and from the SpectraLink 8000 Wireless Telephones are intercepted by the SVP Server and encapsulated for prioritization as they are routed to and from an IP telephony server.

SpectraLink Voice Priority (SVP) and Quality of Service

SpectraLink Voice Priority (SVP) is the SpectraLink quality of service (QoS) mechanism that is implemented in the wireless telephone and AP to enhance voice quality over the wireless network. SVP gives preference to voice packets over data packets on the wireless medium, increasing the probability that all voice packets are transmitted efficiently and with minimum delay. SVP is fully compatible with IEEE 802.11b standards.

SpectraLink 8000 SVP Server Models

The SVP Server is available in three models. Which model is selected for your facility depends on current and expected capacity. All SVP Servers within a subnet must be the same model type.

- SVP100: Serves 80 calls simultaneously.
- SVP020: Serves 20 powered-on handsets.
- SVP010: Serves 10 powered-on handsets.

See the following capacity tables for multiple SVP Server system capacities.

All SVP Server models are installed, configured and administered according to the instructions in this document. The model information is available on the Software Version screen. See Chapter 6 *Troubleshooting via System Status Menu*, section *Software Version*.

The Timing Function

SVP Servers provide the connection or "gateway" to the IP PBX for the wireless telephones and the "timing" function for active calls. This "gateway" function is distributed across the SVP Servers.

The number of active SVP Servers is determined dynamically. Whenever SVP Servers are added to or removed from the system, the distribution of the "timing" function for active calls is affected.

Multiple SVP Servers

Multiple SVP Server environments are those which have more than one SVP Server. Up to four SVP010 models or up to two SVP020 models may be installed in any one subnet. Up to 16 models of SVP100 Servers may be installed in any one subnet. All SVP Servers must be in the same subnet.

When more than one SVP Servers are installed, the wireless telephone load is balanced across the available Servers, both for the communication path between the SVP Server and the wireless

telephones, and between the SVP Server and the PBX (or other far-end device).

SVP Server availability

A SpectraLink handset registers to a single SVP Server the first time it is powered on. Once the handset has contacted this Registration Server, it obtains a list of all SVP Servers in the system. The handset then maintains this list in non-volatile memory and updates it only when rebooted. When a handset later attempts to check in and cannot contact the ordained Registration Server, it will then fall back to its list of other Servers and attempt to check in elsewhere. After the handset has successfully checked into the system once, it never requires that the Registration Server be present unless the handset is reconfigured back to factory defaults, or the entire system of SVP Servers is changed out. See section *Swapping/Adding/Deleting SVP Servers*.

Registration Server identification

The handsets identify the SVP Server in three possible ways. These are outlined in the *Administration and Configuration* document for the handset model(s) and the IP protocol being used in your facility. Essentially, the SVP Server can be identified by a static IP address in the Admin menu, by a DHCP option 151 specification, or by a DNS query of "SLNKSVP2". The address found identifies the Registration Server.

Multiple SVP Server Capacities

The system capacity of each SVP Server model is shown in the tables below. Note that SVP Server models may not be combined within one subnet.

SpectraLink SVP010 and SVP020 Server capacity

The system capacity of the SVP010 and SVP020 is measured by number of powered-on handsets. If this number exceeds the maximum, the handset that cannot be served will display an error and will not connect to the SVP Server. Other handsets will not be affected.

Number of SVP Servers	Number of handsets	
	SVP010	SVP020
1	10	20
2	20	40
3	30	N/A
4	40	N/A

SpectraLink SVP100 Server capacity

The capacity of the SVP100 Server is determined by active calls. The table below shows the capacity of an IP gateway in a multiple-SVP Server environment. The table shows the total possible calls at 100% active calls. However, since it is unlikely that all handsets will be in use at the same time, the table then analyzes the number of handsets that could be installed in any given system where 10%, 15% or 20% of the handsets are in active calls at any one time. The calculations are not linear due to the Erlang¹ calculation for telephony traffic. The

¹ An *Erlang* is a unit of telecommunications traffic measurement. Strictly speaking, an Erlang represents the continuous use of one voice path. In practice, it is used to describe the total traffic volume of one hour.

Erlang traffic measurements are made in order to help telecommunications network designers understand traffic patterns within their voice networks. This is essential if they are to successfully design their network topology and establish the necessary trunk group sizes.

Erlang traffic measurements or estimates can be used to work out how many lines are required between a telephone system and a central office (PSTN exchange lines), or between multiple network locations.

Please visit www.erlang.com for additional information.

possible installed handsets figures are approximate and meant as a guideline and not as an absolute recommendation for any facility.

Number of SVP Servers	Number of calls possible per Server	Total possible installed handsets @ 100% in active calls	Erlang	Possible installed handsets		
				@ 10% in active calls	@ 15% in active calls	@ 20% in active calls
1	80	80	65	500	433	325
2	64	128	111	1000	740	555
3	60	180	160	1500	1067	800
4	58	232	211	2000	1407	1055
5	57	285	262	2500	1747	1310
6	56	336	312	3000	2080	1560
7	56	392	367	3500	2447	1835
8	55	440	415	4000	2767	2075
9	55	495	469	4500	3127	2345
10	55	550	524	5000	3493	2620
11	55	605	578	5500	3853	2890
12	54	648	621	6000	4140	3105
13	54	702	674	6500	4493	3370
14	54	756	728	7000	4853	3640
15	54	810	782	7500	5213	3910
16	54	864	836	8000	5573	4180

Notes on System Configuration



In an IP system using subnets to differentiate telephony areas, each subnet must have its own APs. Each subnet may require an SVP Server to maintain voice quality, but this depends on traffic volume and router capacity.

Multiple SVP Server environments are those which have more than one SVP Server.

SVP Server models may not be combined within one subnet. More than one SVP Server model type may be used within a facility if installed on different subnets.

Wireless telephones cannot roam with uninterrupted service between subnets unless specific LAN components are present. Certain AP/Ethernet switch combinations establish a layer-2 tunnel across subnets that enables the handsets to roam. Without this capability, any call in progress will be dropped when the user moves out of range and the handset must be power cycled in order to resume functionality in the new subnet area.

Please see *Best Practices for Deploying Enterprise-Grade Wi-Fi Telephony* for detailed configuration information when installing multiple SVP Server models across several different subnets.



IP multicast addresses are used when SpectraLink i640 and 8030 Wireless Telephones are installed. This requires that multicasting be enabled on the subnet used for the SpectraLink 8000 Wireless Telephones, SVP Server, and telephony gateways.

Routers are typically configured with filters to prevent multicast traffic from flowing outside of specific domains. The wireless LAN can be placed on a separate VLAN or subnet to reduce the effects of broadcast and multicast traffic from devices in other network segments.



The SVP Server requires a Cat. 5 cable connection between its network port and the Ethernet switch. The SVP Server auto-negotiates to the type of port on the Ethernet switch and supports 10Base-T, 100Base-T, full-duplex and half-duplex port types.

System Diagram

The following diagram shows multiple SVP Servers residing on a network with an IP telephony gateway and IP telephony server, wireless LAN APs, and Ethernet switch:

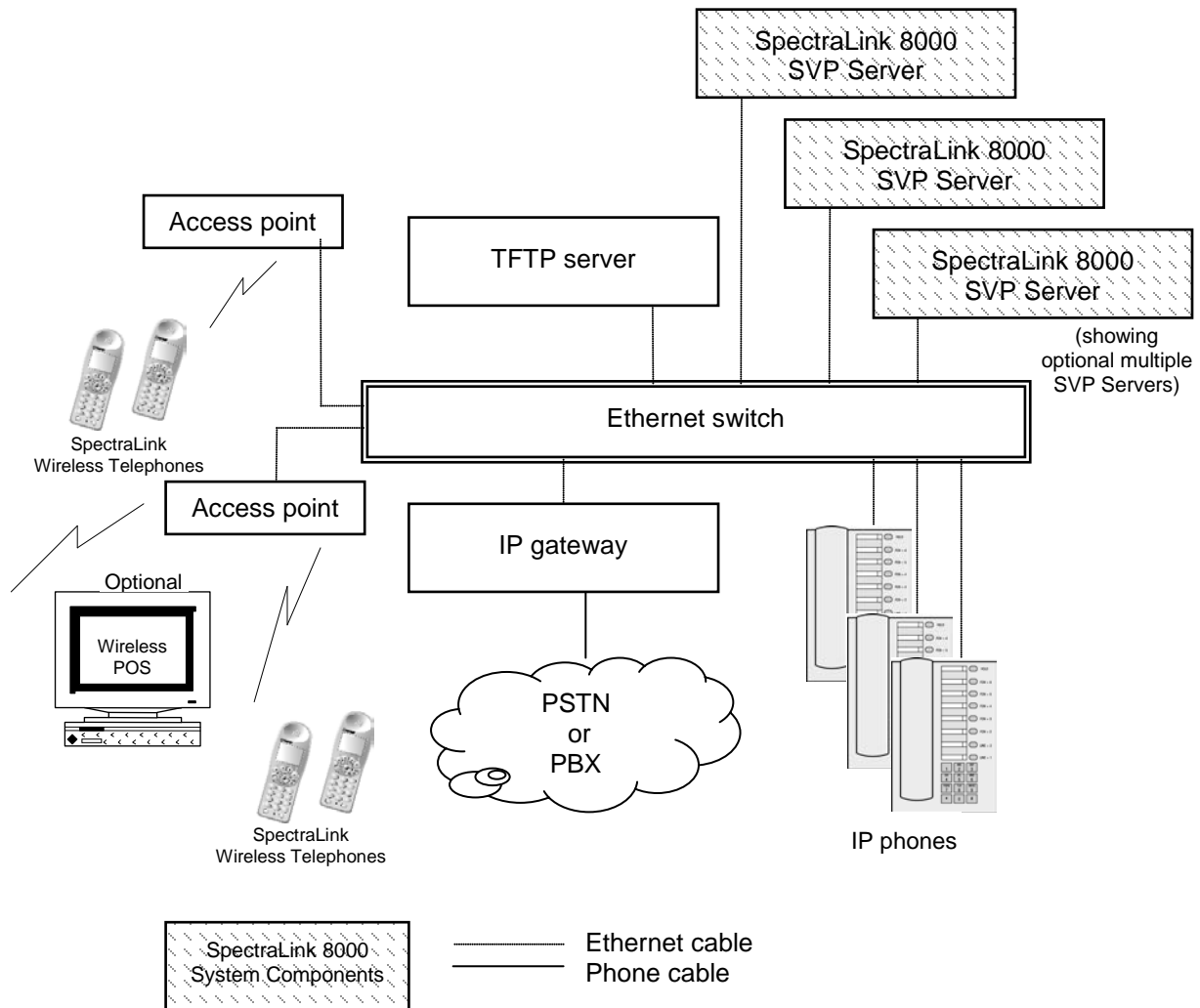

SpectraLink 8000 System Integrated into IP Telephony System

System Components

SpectraLink e340/h340/i640 and 8020/8030 Wireless Telephones

Employees can carry wireless telephones to make and receive calls as they move through the WLAN coverage area. The wireless telephones are to be used on-premises; they are not cellular or satellite phones. Just like wired telephones, they can receive calls directly, receive transferred calls, transfer calls to other extensions, and make outside and long distance calls (subject to the restrictions applied in your facility.)

Access points

Supplied by third party vendors, APs provide the connection between the wired Ethernet LAN and the wireless (802.11) LAN. APs must be positioned in all areas where wireless telephones will be used. The number and placement of APs will affect the coverage area and capacity of the wireless system. Typically, the requirements for use of SpectraLink 8000 Wireless Telephones are similar to those of wireless data devices. Contact Polycom, or a certified Polycom distributor, for specific information about your facility's needs.

The SpectraLink 8000 System must connect to APs that utilize SpectraLink Voice Priority (SVP). Contact Polycom, or a certified Polycom distributor, to verify that your AP and its software version are supported.

Ethernet switch

A component in the wired Ethernet LAN infrastructure. Switches interconnect multiple network devices, including APs and other components. Ethernet switches are required to provide the higher performance network connections needed to handle combined voice and data traffic.

Router

A router is an optional component in the wired Ethernet LAN infrastructure that separates a wired LAN into segments so that network traffic is restricted to those segments that are directly involved in the communication. Installation of a network router is recommended in larger networks, where there may be significant network traffic not related to the wireless LAN. A router will isolate the wireless LAN from the associated wired LAN so that they are not impacted by each others' traffic. The SVP Servers, the APs, and their associated Ethernet switch must all be on the same "side" of the router.

SpectraLink 8000 SVP Server

The SVP Server manages call network traffic as detailed in this document.

Administrative computer

An administrative computer is required for setup and maintenance of the SVP Server. This computer may be temporarily connected directly to the component or to the network; a dedicated computer is not required. Some installations use a laptop to configure and maintain system components.

TFTP server

Required in an IP system to distribute software to the wireless telephones and SVP Server. May be on a different subnet than the IP gateway, IP telephony server, and APs.

The Front Panel of the SVP Server

The SVP Server's front panel contains ports to connect to power, the LAN, and to an administrative computer via an RS-232 port. Status LEDs supply information about the SVP Server's functioning.

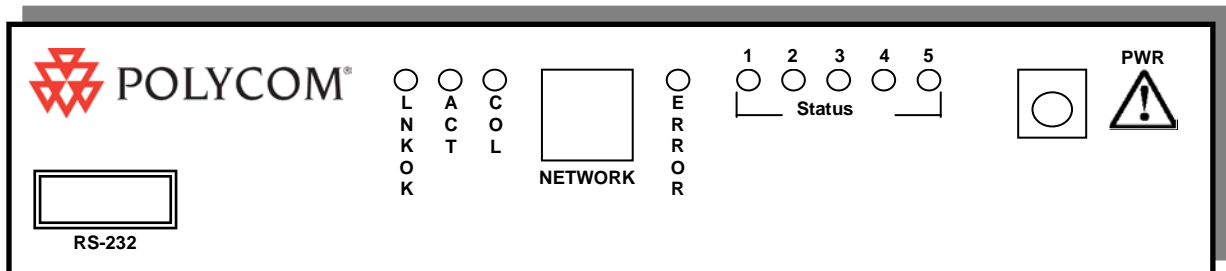

RS-232 Port: male DB-9 connector (DTE) used for RS-232 connection to a terminal, terminal emulator, or modem for system administration.

LEDs

LNKOK: Lit when there is a network connection.

ACT: Lit if there is system activity.

COL: Lit if there are network collisions.

NETWORK: Port to wired (Ethernet) LAN.

ERROR: Lit when the system has detected an error.

STATUS: Indicate system error messages and status.

1: Heartbeat, indicates gateway is running.

2: If active calls.

3: SVP Server is locked.

4: Currently unused.

5: This SVP Server is the cluster master.

PWR (power jack): Connects to the AC adapter supplying power to the system.



Use only the Polycom-provided Class II AC Adapter with output 24V DC, 1A.

Note that the model designation may be found on the label which is on the side of the SVP Server.

Installing the SpectraLink 8000 SVP Server

As shown in the system diagram, the SVP Server is connected to the Ethernet switch. The specifications covered here allow for great flexibility in physical placement of the components within stated guidelines.

See the *Configuration and Administration* document for your vendor's IP system for information on LAN requirements, network infrastructure and IP addressing.

This unit must be installed by a service person familiar with the installation of electronic equipment.

Do not power up the unit before it has been properly grounded to a protective earth. See *Grounding instructions* below.

Required Materials

The following equipment must be provided by the customer.

- Power outlet – AC adapter provided by Polycom.
- Backboard space – the SVP Server is designed to be wall-mounted to ¾" plywood securely screwed to the wall.
- Screws – required to mount the SVP Server to the wall. Four #8 3/4" panhead wood screws (or similar device) are required.
- Cat. 5 cable – RJ-45 connector at the SVP Server. Connection to Ethernet switch.
- Grounding materials per section below *Grounding Instructions*.

Locate the SVP Server

The SVP Server measures approximately 4 x 12.5 x 7 inches, and weighs about five pounds. The unit can be wall-mounted, vertically or horizontally, over $\frac{3}{4}$ " plywood. The SVP Server can also be rack-mounted using a rack-mount kit (sold separately).

Locate the SVP Server in a space with:

- Sufficient backboard mounting space (for wall mount) and proximity to the LAN access device (switched Ethernet hub) and power source.
- Easy access to the front panel, which is used for cabling.
- A maximum distance of 325 feet (100 meters) from the Ethernet switch.

Install the SVP Server

The SVP Server may be mounted on a rack or to a wall.

Mount the SVP Server on a rack

The rack-mount kit is designed for mounting equipment in a standard 19-inch rack and should contain the following equipment:

- Mounting plates – two for each SVP Server to be mounted.
- Screws – four rack-mount screws for each SVP Server to be mounted.

To rack-mount the SVP Server:

1. Remove the corner screws from the SVP Server.
2. Screw the U-shaped end (round screw holes) of the two mounting plates to the SVP Server.
3. Screw the other end of the two mounting plates (oblong screw holes) to the rack.
4. Repeat steps 1-3 for each additional SVP Server. The mounting plate is designed to provide the correct minimum spacing between units. When mounting multiple units, stack the units in the rack as closely as possible.

Mount the SVP Server to a wall

The SVP Server can be mounted either horizontally or vertically.

To mount the SVP Server to a wall:

1. Using a 1/8-inch drill bit, drill four pilot holes, on 1.84-inch by 12.1-inch centers (approximately equivalent to 1-13/16" by 12-1/8").
2. Insert the #8 3/4-inch screws in the pilot holes and tighten, leaving a 1/8-inch to 1/4-inch-gap from the wall.

Grounding instructions



The metal chassis of this unit may contain leakage currents (i.e., "touch" current) which is cumulative when multiple units are connected together to form a system. To prevent the summation of leakage currents from being present on exposed metal surfaces, the following installation procedure must be followed.

All system units must be grounded to a protective earth by means of the grounding stud located on the rear panel. Refer to the illustration below for recommended continuity connection.

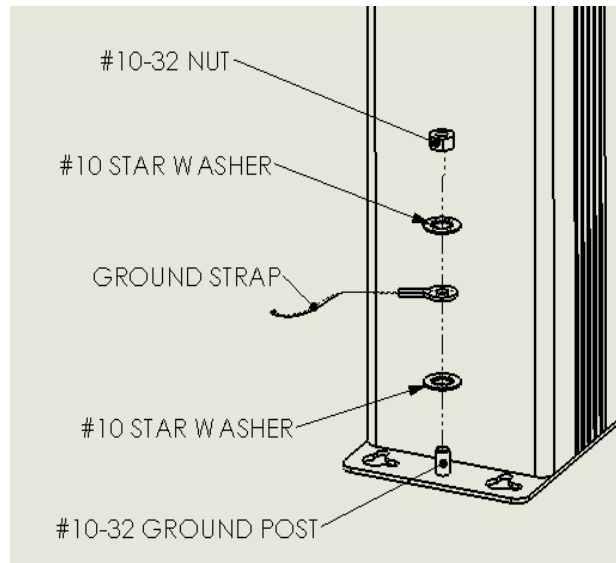

No more than 15 units may be grounded through one connection to the protective earth ground. Systems involving more than 15 units must be broken up into groups of 15 or fewer units with each group provided with an independent protective earthing conductor.

Connect SVP Server to LAN

Using a Cat. 5 cable, connect the **NETWORK** port on the SVP Server to the connecting port on the Ethernet switch.

Connect power

1. Once the units have been properly grounded, connect the power plug from the AC adapter to the jack labeled **PWR** on the SVP Server.



Use only the provided Class II AC Adapter with output 24V DC, 1A.

2. Plug the AC adapter into an 110V AC outlet to apply power to the SVP Server.
3. Verify that leakage current ("touch" current) is below 250 μ A rms on exposed metal surfaces.
4. If leakage is excessive, power off the system and re-verify ground path continuity.
5. The system will cycle through diagnostic testing and the LEDs will blink for about one minute. When the system is ready for use:
 - The **ERROR** LED should be off.
 - **Status 1** should be blinking.

Configuring the SpectraLink 8000 SVP Server

During initial setup of the SVP Server the IP address is established and the maximum number of active calls per AP is set. Optionally, you may enter a hostname and a location for software updates via TFTP.

Connecting to the SVP Server

The initial connection to the SVP Server must be made via a serial connection to establish the SVP Server's IP address. After the IP address is established, connection to the SVP Server may be done via the network using telnet. It is recommended that the basic setup actions occur while the serial connection is made.

Connect via the serial port

1. Using a DB-9 female, null-modem cable, connect the SVP Server to the serial port of a terminal or PC.
2. Run a terminal emulation program (such as HyperTerminal™) or use a VT-100 terminal with the following configuration:
Bits per second: 9600
Data bits: 8
Parity: None
Stop bits: 1
Flow control: None
3. Press Enter to display the SVP Server login screen.
4. Enter the default login: admin and default password: admin. These are case sensitive.
5. The **NetLink SVP-II System** menu will display.

Connecting via telnet



Telnet can only be used after the SVP Server's IP address is configured.

The telnet method of connection is used for routine maintenance of the SpectraLink Server for both local and remote administration, depending on your network.

To connect via telnet, run a telnet session to the IP address of the SVP Server. Once you connect and log in, the **NetLink SVP-II System** menu displays.

The NetLink SVP-II System Menu

The main menu displays as shown here:

```
NetLink SUP-II System
Hostname: [SUPV2_1], Address: 10.8.0.61

System Status
SUP-II Configuration
Network Configuration
Change Password
Exit

Enter=Select      ESC=Exit      Use Arrow Keys to Move Cursor
```

System Status

Menu for viewing error messages, status of operation and software code version.

SVP-II Configuration

Allows you to set the mode and reset the system.

Network Configuration

Allows you to set network configuration options, including IP address and hostname.

Change Password

Allows you to change the password for SVP Server access.

Network Configuration

The IP address and other network settings are established via the **Network Configuration** screen. This is also where you may optionally establish a hostname and enter the IP address of the location of any software updates you may obtain from Polycom. See Chapter 5 *Software Maintenance* for more information about installing software updates via TFTP.

Scroll to **Network Configuration** and select by pressing Enter. A screen similar to the following appears:

```

                                Network Configuration
                                Hostname: [SVPO20_1], Address: 10.8.0.61

Ethernet Address (fixed):      00:90:7A:02:8F:AB
IP Address:                    10.8.0.61
Hostname:                     SVPO20_1
Subnet Mask:                  255.0.0.0
Default Gateway:              10.0.0.90
SVP-II TFTP Download Master:  10.0.0.3
Primary DNS Server:           NONE
Secondary DNS Server:         NONE
DNS Domain:                   NONE
WINS Server:                  10.13.0.1
Workgroup:                    WORKGROUP
Syslog Server:                10.0.0.31
Disable Telnet service:       N
Maintenance Lock:             N

Enter=Change  S=SendAll  ESC=Exit    Use Arrow Keys to Move Cursor

```

Note the navigation options at the bottom of the screen. Press Enter to change a value, ESC to exit the screen, and the arrow keys to move the cursor.

Navigation Option

SendAll

In an IP system with multiple SVP Servers, the **SendAll** option is provided to speed configuration and to ensure identical settings. The **S=SendAll** option allows you to send that configuration parameter to every SVP Server on the LAN. **SendAll** can only be used after the IP address is established on EACH SVP Server via the serial connection.

If you anticipate identical settings across the LAN, set just the IP address and custom hostname (if desired) for each SVP Server using the initial serial connection. Then connect via the LAN and configure one SVP Server, pressing **S** to use the **SendAll** option to set identical configuration options for all other SVP Servers in the system.

If **SendAll** is to be utilized in your system, all SVP Server passwords must be identical. **DO NOT CHANGE THE PASSWORD AT THE INITIAL CONFIGURATION IF THE **SendAll** OPTION IS DESIRED.** Use the default password and change it globally if desired after a LAN connection is established for all SVP Servers.

If independent administration of each SVP Server is desired, the passwords may be set at initial configuration.

The following options must be configured:

Configuration Options

All options must be given an entry, but some options do not need to be configured. If no configuration is desired, use the default setting **NONE**. If you want to clear a configuration, overwrite it with **NONE**.

The following options must be configured:

IP Address

Enter the IP address of the SVP Server, defined by your network administrator. Enter the complete address including digits and periods. **DHCP** may be entered.

The SVP Server will automatically lock for maintenance if the IP address is changed. When this **Maintenance Lock** occurs, the SVP Server must be reset upon exit. All active calls are terminated during a reset.

Hostname

(Optional) change the default host name, if desired. This is the name of the SVP Server to which you are connected, for identification purposes only. You cannot enter spaces in this field. Valid characters are numbers 0-9, letters a-z A-Z, or an underscore _.



The host names for each SVP Server and OAI Gateway on the system must be unique.

Subnet Mask

The network administrator must define the subnet mask.

Default Gateway

The IP address of a router on the local subnet.

SVP-II TFTP Download Master

This entry indicates the source of software updates for the SVP Server. See Chapter 5 *Software Maintenance* for more information. Valid source location entries are:

- **NONE:** disables.
- **IP Address:** The IP address of a network TFTP server that will be used to transfer software updates to the SVP Server.

DNS Server and DNS Domain

These settings are used to configure Domain Name services. Consult your system administrator for the correct settings. These can also be set to **DHCP**. This will cause the DHCP client in the SVP Server to attempt to automatically get the correct setting from the DHCP server. The DHCP setting is only valid when the IP address is also acquired using DHCP.

WINS Servers

These setting are used for Windows Name Services. Consult your system administrator for the correct settings. These can also be set to **DHCP**. This will cause the DHCP client in the SVP Server to attempt to automatically get the correct setting from the DHCP server. The

DHCP setting is only valid when the IP address is also acquired using DHCP.



When the name services are set up correctly, the SVP Server can translate hostnames to IP addresses. Using telnet, it is also possible to access the SVP Server using its hostname instead of the IP address.

Workgroup

As set in WINS.

Syslog Server

Logging may be set to either **DHCP** (see **DNS** above), an [IP address] or **NONE**. If Syslog is set, a message is sent to the syslog server when an alarm is triggered.

Disable Telnet service

Prevents Telnet access into the SVP Server. Reset the SVP Server for the change to take effect. Upon reset the Telnet protocol server is not started.

The SVP Server must be reset in order to set the configuration options. If the SVP Server is in **Maintenance Lock**, you must manually reset it by selecting the **Reset** option in the **SVP-II Configuration** screen and then pressing Y upon exit.

SVP Server Configuration

The **SVP-II Configuration** screen is where you set the mode of the SVP Server. It is also where you can lock the SVP Server for maintenance and reset the SVP Server after maintenance. The type of gateway you are using determines the mode of the SVP Server.

From the main menu, scroll to **SVP-II Configuration** and select by pressing Enter.

```

SUP-II Configuration
  Hostname: [OJK_SUPII_050307], Address: 172.29.76.40

Phones per Access Point: 5
802.11 Rate: Automatic
First Alias IP Address: 172.29.76.41
Last Alias IP Address: 172.29.76.44
Enable H.323 Gatekeeper: N
SUP-II Mode: Netlink IP
Ethernet link: auto-negotiate
Check-in throttling (0-4): 0
Missed ding limit (3-10): 3
System Locked: N
Maintenance Lock: N
Inactivity Timeout (min): 19
QoS Configuration
Reset
Reset all SUP servers

Enter=Change  S=SendAll  ESC=Exit  Use Arrow Keys to Move Cursor

```

Ensure the **SVP-II Mode** is set to **NetLink IP** as shown in the above screen.

The following options must be configured:

Phones per Access Point

AP specifications are detailed in the *Configuration Notes* for each brand and type. Refer to these notes when entering the number of simultaneous calls supported for your type.

802.11 Rate

Select 1MB/2MB to limit the transmission rate between the wireless telephones and APs. Select **Automatic** to allow the wireless telephone to determine its rate.

First Alias IP Address/Last Alias IP Address

The SVP Server uses an IP address when acting as a proxy for the wireless telephone. Therefore, one alias IP address is required for every installed Wireless Telephone. These IP addresses must be entered as a range and must be assigned solely for this purpose.

When multiple SVP100 Servers are installed, a different range must be configured in each SVP Server. In determining how many addresses to configure per SVP Server, use this formula: (# of handsets / # of SVP Servers) + 30%. This formula will accommodate the possibility of unequal distribution of handsets among the available SVP Servers.



All alias addresses must be on the same subnet as the SVP Server and cannot be duplicated on other subnets or SVP Servers. There is no limit to the number of addresses that can be assigned, but the capacity of each SVP Server is 500 wireless telephones.



Alias IP Addresses are not necessary in Cisco systems.

Enable H.323 Gatekeeper

In certain H.323 protocol systems, the SVP Server may function as a gatekeeper. Enter Y to have the SVP Server function as the gatekeeper in the H.323 protocol environment.

Ethernet link

The SVP Server will auto-negotiate unless there is a need to specify a link speed.

Check-in throttling

The check-in throttling option regulates the number of handsets that can check-in simultaneously. The error **Maximum payloads reached** is caused by a massive check-in that has overwhelmed the server. If persisting, throttling may be raised. However, a setting that is too high may slow check-in performance. The option allows for a setting from 0 to 4, with 0 being the least amount of throttling and 4 being the most. Consult with Customer Support for help in determining if throttling is advised for your system.

Missed ding limit

The **Missed ding limit** defaults to 3 and should be left at this setting unless advised by Customer Service to raise or lower it. The DING message is a proprietary method of communication among system elements. This setting is designed to assist service engineers in fine-tuning system performance and should not be changed without their consultation.

System Locked

This option is used to take the system down for maintenance. The default entry is **N** (No). Set it at **Y** (Yes) to prevent any new calls from starting. Return to **N** to restore normal operation.



Load balancing enables a locked SVP Server to distribute idle handsets to other SVP Servers in the cluster. Existing calls will not be interrupted and the SVP Server will become idle once all calls are ended and idle phones are transferred to another SVP Server.

Maintenance Lock

The system automatically sets this option to **Y** (Yes) after certain maintenance activities that require reset, such as changing the IP address. **Maintenance Lock** prevents any new calls from starting. Note that the administrator cannot change this option. It is automatically set by the system. Reset the system at exit to clear **Maintenance Lock**.

Inactivity Timeout (min)

Set the number of minutes the administrative module can be left unattended before the system closes it. This number can be from 1 to 100. If it is set to zero (0), the administrative module will not close due to inactivity.

QoS Configuration

Select this option to set the DSCP tags. See *QoS Configuration* section below.

Reset System

If this option is selected, you will be prompted to reset the SVP Server upon exiting this screen.

Reset all SVP Servers

If this option is selected, you will be prompted to reset all SVP Servers upon exiting this screen. This is necessary if you have changed configurations on other SVP Servers by using the **SendAll** option.



The SVP Server should be reset at the end of any maintenance procedure that requires a reset either via **Maintenance Lock** or manually via **Reset System**.



Note that resetting the SVP Server will terminate any calls in progress. See the Network Status section for information on determining if active calls exist.

QoS Configuration

DSCP tags set packet priorities for QoS.

```

                                QoS Configuration
                                Hostname: [slnk-03e3961], Address: 10.13.0.127

                                Traffic Class DSCP Tag
                                -----
                                Administration Default
                                WT (In call) Default
                                WT (Standby) Default
                                RTP Default
                                PBX Default
                                Inter-SVP2 Default

                                Enter=Change  S=SendAll  ESC=Exit    Use Arrow Keys to Move Cursor
  
```

DSCP Tag

DSCP (Differentiated Services Code Point) is a QoS mechanism for setting relative priorities. Packets are tagged with a DSCP field in the IP header for type of service. The decimal value may be set as a number from 0-63 and may be different for each traffic class listed on the screen.

- **Administration** tags set the priority for telnet, TFTP, and other administrative traffic. Administrative traffic can have the lowest priority because it does not require voice quality.
- **WT (In call)** traffic requires voice quality and may be set to a higher priority than **WT (Standby)** traffic.
- **RTP** traffic is the audio traffic to the IP PBX. It requires voice quality.
- **PBX** traffic is not audio to the PBX.
- **Inter-SVP2** traffic is the information-passing protocol that SVP Servers use to communicate with each other.

When forwarding packets, the SVP Server overwrites the received DSCP value. The final DSCP tag for packets in each of the traffic classes are assigned a DSCP value based on the following rules and per the table below.

- Packets are tagged with the corresponding Traffic Class value entered in the QoS Configuration menu if the value for the Traffic Class is set to something other than Default.
- Otherwise, packets are tagged with the Administration Traffic Class value (the first item in the QoS Configuration Menu) if the corresponding Traffic Class is set to Default and the Administration Traffic Class value is set to something other than Default.
- Finally, packets are tagged with the Default value of the corresponding Traffic Class if both the corresponding Traffic Class and the Administration Traffic Class values are set to Default. The following table lists the Default values for the DSCP tags.

Traffic Class	Default
Administration Priority Low	0
WT (In call) Priority High	4
WT (Standby) Priority Med	0
RTP Priority High	4
PBX Priority Med	0
Inter-SVP2 Priority Med	0



Default DSCP settings will mark traffic for Best Effort handling under normal circumstances. Please consider changing these values based on the recommended QoS settings from your network hardware manufacturer to achieve prioritization for your voice traffic.

Change Password

If desired, the password to access the SVP Server may be changed.

A password must meet the following requirements:

- It must be more than four characters, but cannot exceed 16 characters.
- The first character must be a letter.
- Only numbers and letters are allowed.
- No dashes, spaces, or punctuation marks, etc. are allowed.

Select **Change Password** from the main menu. A screen similar to the following will appear:

```

Change Password
Hostname: [SUPU2_1], Address: 10.8.0.61

Old Password *****
New Password *****
Confirm New Password *****
Set Password
Set Password on all SUP servers

Enter=Select      ESC=Exit      Use Arrow Keys to Move Cursor

```

Enter the information and either select **Set Password** or press the S key to set the new password.

If you are using the **Send All** option as described above in Network Configuration every SVP Server must have the same password. Please review that section for additional information about using **Send All**.

If you forget a password, call Polycom Customer Service for assistance.

Swapping/Adding/Deleting SVP Servers

Whenever an SVP Server is removed from the system, wireless telephones that are using the SVP Server will be affected and calls may be lost. If the removal of the SVP Server is intentional, the administrator should lock and idle the system prior to removing an SVP Server.



Load balancing enables a locked SVP Server to distribute idle handsets to other SVP Servers in the cluster. Existing calls will not be interrupted and the SVP Server will become idle once all calls are ended and idle phones are transferred to another SVP Server.

Adding an SVP Server

A new SVP Server is detected within two seconds of being added to the system (booted/configured/connected). When detected, wireless telephones not active in a call will gradually be forced to reboot and check in again. Any wireless telephone in a call will immediately switch to the SVP Server that should provide its "timing" function. This switch should not be noticeable to the user since it is similar to a normal handoff between APs. When the wireless telephone ends the call, it will eventually be forced to reboot and check in again. Only a few handsets at a time are rebooted to prevent excessive check in traffic on the network. Handsets scheduled to be rebooted can still make calls and will be rescheduled for reboot when the call is ended.

Removing an SVP Server

The preferred method for removing an SVP Server from an active system is to first lock the SVP Server. When an SVP Server is locked for removal from the system, load balancing enables the locked SVP Server to distribute idle handsets to other SVP Servers in the cluster. Active calls will not be interrupted. The locked SVP Server will

become idle once all calls are ended and idle handsets are registered to other SVP Servers. Once all handsets have been moved---as evidenced by the number of **Telephones in Use** on the **Network Status** screen---the idle SVP Server may be unplugged and removed from the system.

During this process, there is a short period where a handset registered on a locked SVP Server may attempt to initiate a call before it is re-registered to another SVP Server. In this case, if there is an unlocked SVP Server in the cluster, the SVP Server will tell the handset to reboot. As it reboots, the handset will check-in with an available SVP Server and the user may then start a call. Handsets registered on unlocked SVP Servers are not affected.

Of course if a system only has one SVP Server, no calls will be possible until the removed SVP Server is replaced.

SVP Server Failure

If an SVP Server becomes unable to manage calls or fails, any handset registered to that SVP Server loses service (and any calls) and will reboot within 30 seconds. After rebooting, the handset will register with another SVP (if there is one available) and be able to make new calls. Handsets not registered on the failed SVP may experience a few seconds of disruption in audio but are otherwise unaffected.

Software Maintenance

The SVP Server uses proprietary software programs written and maintained by Polycom Corporation. The software versions that are running on the system components can be displayed via the **System Status** screen.

You may obtain information about software updates from Polycom or its authorized dealer.

At startup the SVP Server uses TFTP to check the software version it is running against the version in the TFTP location. If there is a discrepancy, the SVP Server will download the version in the TFTP location. See the *Configuration and Administration* document for your vendor's IP system for more information about using TFTP.

Software Updates

Lock the SVP Server in the **SVP-II Configuration** screen prior to updating the software. In multiple SVP Server systems, all SVP Servers must be locked and upgraded at the same time.

Downloads for the SVP Server are available from http://www.polycom.com/usa/en/support/voice/wi-fi/spectralink_8000_svp_server.html.

After software updates are obtained from Polycom, they must be transferred to the TFTP location in the LAN to update the code used by the SVP Server(s).



Note that locking the SVP Server will prevent new calls from starting. All calls in progress will be terminated when the SVP Server is reset.

Troubleshooting via System Status Menu

Information about system alarms, and network status displays on various screens accessed through the **System Status Menu** screen, which is opened from the main menu of the SVP Server. See the previous sections for directions on how to connect to the SVP Server and navigate to the **System Status Menu**.

```
System Status Menu
Hostname: [SUPV2_1], Address: 10.8.0.61

Error Status
Network Status
Software Versions
Gatekeeper Database

Enter=Select      ESC=Exit      Use Arrow Keys to Move Cursor
```

Error Status - Displays alarm and error message information.

Network Status - Displays information about the Ethernet network to which the SVP Server is connected.

Software Versions - Lists the software version for each SpectraLink component.

Gatekeeper Database - Not used in a SIP environment.

Options on the **System Status Menu** provide a window into the real time operation of the components of the system. Use this data to determine

system function and to troubleshoot areas that may be experiencing trouble.

Error Status

The **Error Status** screen displays any alarms that indicate some system malfunction. Some of these alarms are easily remedied and others require a call to Polycom's Customer Support Department.

From the **System Status Menu**, select **Error Status**. The screen displays active alarms on the SVP Server.

The following table displays the list of alarms and a description of the action to take to eliminate the alarm.

Alarm Text	Action
Maximum payload usage reached	Reduce usage, clear alarm ²
Maximum telephone usage reached	Reduce usage, clear alarm
Maximum access point usage reached	Reduce usage, clear alarm
Maximum call usage reached	Reduce usage, clear alarm
SRP audio delayed	Reduce usage, clear alarm
SRP audio lost	Reduce usage, clear alarm
No IP address	Configure an IP address
SVP Server(s) lost	Reduce usage or replace lost SVP Server. Clear alarm

Press C to clear all clearable alarms.

² If capacity problems persist, additional SVP Servers may need to be added to the system to improve performance.

Network Status

The SVP Server is connected to the Ethernet network, referred to as the LAN or Local Area Network. The information about that connection is provided through the **Network Status** screen.

From the **System Status Menu**, select **Network Status**. The screen displays information about the Ethernet network. This information can help troubleshoot network problems. A sample screen is displayed here.

```

Network Status
Hostname: [SVP02_1], Address: 10.8.0.61

Ethernet Address: 00:90:7A:00:77:15           Net: 100/Full
System Uptime:   6 days, 02:34             Max calls: 80

RX:  bytes   packets  errors  drop  fifo  alignment  multicast
    432891547 4112190    0      0    0      0          1321217

TX:  bytes   packets  errors  drop  fifo  carrier  collisions
    1478261799 1311194    0      0    0      0          0

SUP-II Sockets in Use           (Last / Max):    0 / 10
SUP-II Access Points in Calls (Last / Max):    0 / 2
SUP-II Telephones in Use       (Last / Max):    0 / 1
SUP-II Telephones in Calls     (Last / Max):    0 / 2
SUP-II SRP Audio               (Delay / Lost):  0 / 0
    
```

ESC to Exit

Ethernet Address – MAC address of the SVP Server (hexadecimal).

System Uptime – The number of days, hours and minutes since the SVP Server was last reset.

Net – The type of connection to the Ethernet switch currently utilized. See *SVP100 Capacity* for more information.



Data is transmitted over SpectraLink components by proprietary technology developed by Polycom Corporation. The SpectraLink Radio Protocol (SRP) packets and bytes can be differentiated from other types of transmissions and are used to evaluate system functioning by Polycom customer support and engineering personnel.

RX – Ethernet statistics concerning the received packets during System Uptime.

bytes – bytes received

packets – packets received

errors – Sum of all receive errors (long packet, short packet, CRC, overrun, alignment)

drop – packets dropped due to insufficient memory

fifo – overrun occurred during reception

alignment – nonoctet-aligned packets (number of bits NOT divisible by eight)

multicast – packets received with a broadcast or multicast destination address

TX – Ethernet statistics concerning the transmitted packets during System Uptime.

bytes – bytes transmitted

packets – packets transmitted

errors – Sum of all transmit errors (heartbeat, late collision, repeated collision, underrun, carrier)

drop – packets dropped due to insufficient memory

fifo – underrun occurred during transmission

carrier – carrier lost during transmission

collisions – packets deferred (delayed) due to collision

SVP-II Access Points in Use – APs in use by wireless telephones, either in standby or in a call. ‘Last’ is current, ‘Max’ is the maximum number in use at one time.

SVP-II Access Points in Calls – APs with wireless telephones in a call.

SVP-II Telephones in Use – wireless telephones in standby or in a call.

SVP-II Telephones in Calls – wireless telephones in a call.

SVP-II SRP Audio (Delay) – SRP audio packets whose transmission was momentarily delayed.

SVP-II SRP Audio (Lost) – SRP audio packets dropped due to insufficient memory resources.

Software Version

The SVP Server and wireless telephones utilize Polycom Corporation's proprietary software that is controlled and maintained through versioning. The **Software Version** screen provides information about the version currently running on the SVP Server. This information will help you determine if you are running the most recent version and will assist Polycom engineering and/or customer support in troubleshooting software problems.

This screen also displays the model type.

From the **System Status Menu**, select **Software Version**. A sample screen is displayed here.

```
                Software Version Numbers
      Hostname: [SVP020_1], Address: 10.8.0.61

SVP Type:           020
Hardware Versions:  33/02
Factory Page:       213.001
Downloader:         213.004 (99cd73ee)
Table of Contents: 173.024 (4553d976)
Functional Code:    174.024 (f4ae1d58)
File System:        175.024 (4bfc9a09)

                ESC to Exit
```

Note that the software versions on your system may be different from the versions displayed in the above sample screen.

The table below shows the description, major version numbers, and filenames of the files that are provided when downloading updates.

Name	Major Version Number	Filename
Table of contents	173	svp100.toc
Functional code	174	zvmlinux
File system	175	flashfs

The major version numbers will not change, but minor version numbers to the right of the decimal change with each release. The minor version numbers for these three files must all match, as they do in the screen example (17x.024).

Safety Notices



WARNING: Changes or modifications to this equipment not approved by SpectraLink Corporation may cause this equipment to not comply with part 15 of the FCC rules and void the user's authority to operate this equipment.



WARNING: SpectraLink products contain no user-serviceable parts inside. Refer servicing to qualified service personnel.



IMPORTANT SAFETY INFORMATION

Follow these general precautions while installing telephone equipment:

- Never install telephone wiring during a lightning storm.
- Never install telephone jacks in wet locations unless the jack is specifically designed for wet locations.
- Never touch uninsulated telephone wires or terminals unless the telephone line has been disconnected at the network interface.
- Use caution when installing or modifying telephone lines
- When installing Base Stations outside or in buildings other than the one containing the System Controller, take the following precaution:
If wiring for a Base Station exits a building—whether to reach an outdoor Base Station location or to reach a Base Station in another building—the wiring must be protected at both ends by a Quick Clip Fuse from Illinois Tool Works, Linx Division, model number SCP-2X2. The Quick Clip Fuse replaces the bridging clips on the 66 blocks for all four connections to the non-internal Base Station.